

Electronics - Problem Sheet 1

17 January 2011

1. The density of Cu is 8.92 g/cm^3 and a mole of Cu atoms weighs 63.54 g . Estimate the electron carrier density for copper assuming that each atom contributes one free electron. [Avogadro's number is 6.02×10^{23}]
2. Tungsten (W) is commonly used as a filament material in incandescent light bulbs. The room temperature resistivity of W is $5.6 \times 10^{-8} \text{ } \Omega\text{m}$. Calculate the resistance of a 50 cm long (coiled) W filament having a cross sectional area of $2 \times 10^{-9} \text{ m}^2$ at (a) room temperature and (b) at 2000 K when it emits light [the temperature coefficient of resistivity, α , for W is 0.0045].

3. The circuit shows a battery of emf $\varepsilon = 12 \text{ V}$ and internal resistance $2 \text{ } \Omega$. What are the readings on the ammeter and voltmeter? What is the potential difference across the $4 \text{ } \Omega$ resistor? Hence, find the rate of energy conversion (chemical to electrical), the rate of dissipation of energy in the battery and the net power output of the battery.

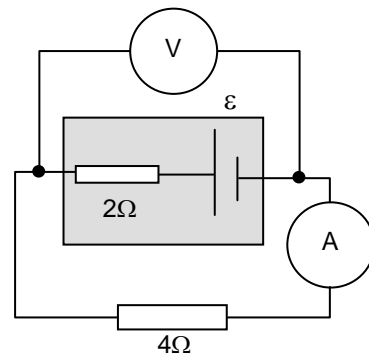

4. You are required to measure the unknown resistance, R using the circuit shown on the right. The voltmeter has a resistance of $10 \text{ k}\Omega$ while the ammeter has a resistance of $2 \text{ } \Omega$. The voltmeter reads 12 V while the ammeter reads 100 mA . What is the value of R and the power dissipated in R ?

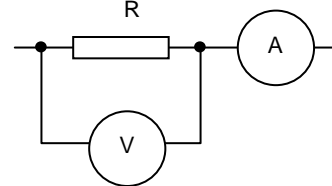

5. The diagram shows three identical lightbulbs connected to a battery of emf ε . How do the brightness of the bulbs compare? Why? What happens if bulb A is removed? What happens if bulb A is replaced but bulb C is removed?

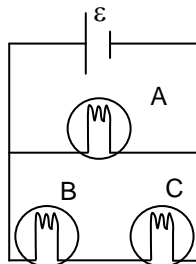

Electronics - Problem Sheet 2

24 January 2011

1. What are the physical principles that underlie Kirchhoff's circuit laws? For the circuit shown below, use Kirchhoff's laws to calculate the current flowing through each of the resistors.

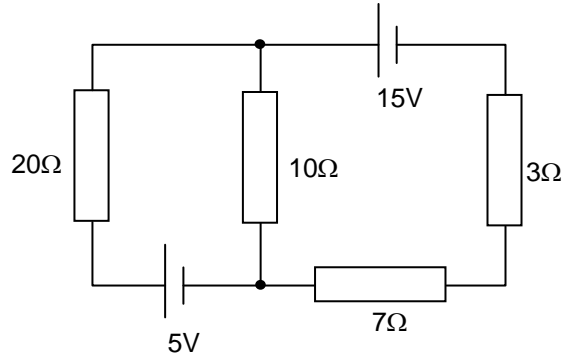

2. Using the principle of superposition calculate the current in the $390\ \Omega$ resistor in the circuit shown below.

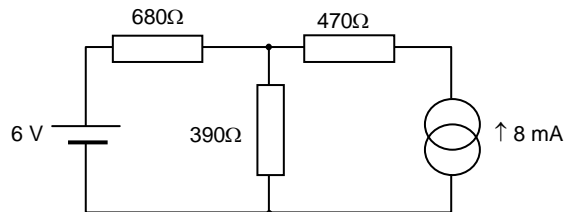

3. For the circuit shown below use the principle of superposition to find the current in the upper $10\ \text{k}\Omega$ resistor.

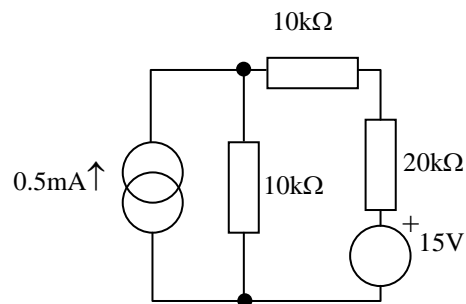

4. Find the Thévenin equivalent of the circuit shown below.

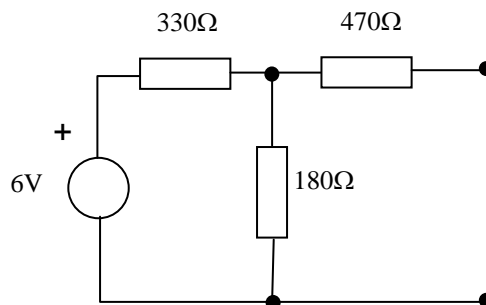

1. An air filled parallel plate capacitor is connected to a 1kV DC supply. The plates have an area of 10 cm^2 and are separated by 1mm. Calculate the capacitance, the charge on each plate and the strength of the electric field between the plates. If the capacitor is disconnected from the DC supply and a 1mm thick slab of glass having the same area as the plates inserted calculate the potential difference across the plates (the relative permittivity of glass is 4.7).
2. Show that the energy stored in a vacuum capacitor with a plate area A and plate separation d is $\frac{Q^2 d}{2\epsilon_0 A}$. If d is now increased by a small amount, dx find an expression for the change in the stored energy.
3. A $10\mu\text{F}$ capacitor C_1 is fully charged with a 200V source. What is the charge on the plates and the energy stored in the capacitor? C_1 is disconnected from the voltage source and attached in parallel with another uncharged capacitor C_2 of value $5\mu\text{F}$. What is the voltage across C_1 and C_2 now? Calculate the total stored energy of the pair and account for any differences with the earlier value.
4. Which of the following statements are true about the inductor shown below which forms part of a circuit? You may assume that $V_a > V_b$.
 - (a) I is from a to b and steady
 - (b) I is from a to b and increasing
 - (c) I is from a to b and decreasing
 - (d) I is from b to a and steady
 - (e) I is from b to a and increasing
 - (f) I is from b to a and decreasing

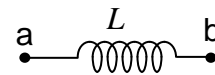

5.

1. Calculate the average and r.m.s values of the sawtooth voltage shown below.

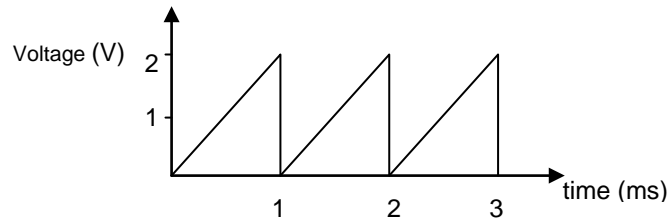

2. A voltage $v(t) = 5 + 2.5 \cos(\omega t + \pi/4)$ is placed across a 1Ω resistor. Calculate the power dissipated in the resistor.
3. Express in a $+jb$ form the phasors $10\angle 60^\circ$; $0.4\angle 12^\circ$; $15 \times 10^3 \angle \pi/6$ rad.
4. Find expressions for the complex impedance of the following combinations of components:

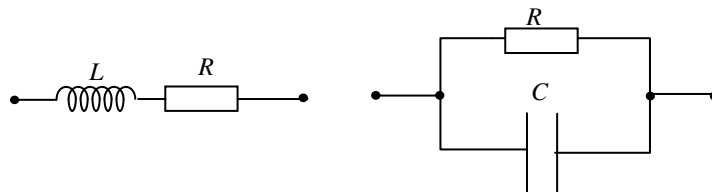

5. A sine wave voltage of amplitude 3V and frequency 12566 rad/s is applied to the RC filter network input shown below. What is the value of the output voltage and what is its phase angle relative to the input?

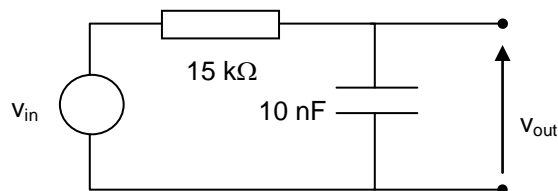

1. The diagram shows a schematic of an operational amplifier which is known to have a large d.c. gain of 10^5 . It is powered by $\pm 9V$.

- (i) What is the relationship between v_0 , v_+ and v_- ?
- (ii) What are the limits on the value of v_0 ?

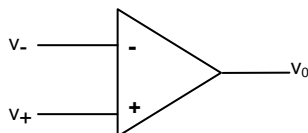

- (iii) Using your answers to (i) and (ii) deduce the useful working range of input voltages to the amplifier.
- (iv) Treating v_+ and v_- as Thévenin sources explain why it is necessary that the amplifier has a high input resistance (impedance)
- (v) If a load resistor R_L is placed across v_0 explain why it is necessary that the amplifier have a small output resistance (impedance)

The op-amp has a frequency dependent gain given by $A=A_0/(1 + jf/f_0)$ where A_0 is the DC gain.

- (vi) Find an expression for the modulus of the gain and calculate its value at (a) f_0 and (b) $10 f_0$
- (vii) Sketch the dependence of the modulus as a function of $\log_{10} f$ indicating the significance of f_0

2. The op-amp circuit of question 1 has now been modified to include a feedback loop and a voltage v_{in} is input to the non-inverting terminal.

- (i) Using your answer for part (i) of question 1 deduce an expression for v_0 at low frequencies
- (ii) Using the expression for the frequency dependent gain given in question 1 show that the value of f_0 increases to $A_0 f_0$ when the feedback loop is included
- (iii) What is v_0 if v_{in} is (a) 5 mV (b) $5 \cos 20\pi f_0 t$ mV (c) $5 \cos 2 \times 10^5 \pi f_0 t$ mV?

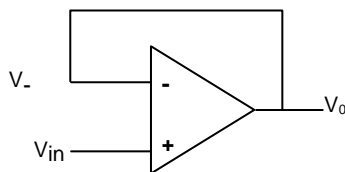

3. The circuit shown below on the left is a voltage divider.

- (i) Find an expression for v' in terms of R_1 , R_2 and v_{in} .
- (ii) Using your result deduce an expression for the voltage appearing at the inverting terminal of the op-amp circuit shown on the right.
- (iii) Using the method applied in question 2 part (i) find an expression for v_0 for this op-amp circuit
- (iv) For $R_1=9 \text{ k}\Omega$ and $R_2= 1 \text{ k}\Omega$ calculate v_0 and the frequency where the gain begins to drop

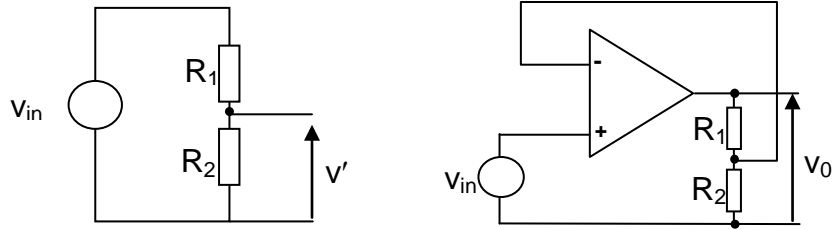

4. The circuit (a) shown below is an example of shunt feedback.

- (i) What is the potential at the point S and explain your reasoning
- (ii) Applying the method used in questions 1 and 3 find an expression for v_0/v_{in} , the closed loop gain of the amplifier
- (iii) What value of R_F would be required to obtain a closed loop gain of 20 if $R_{in} = 1.5 \text{ k}\Omega$?

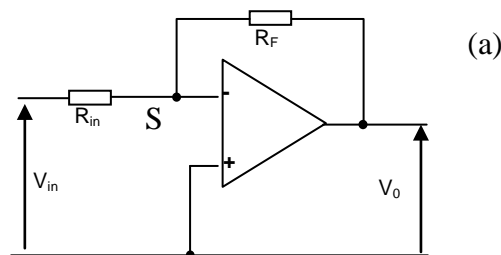

- (iv) Determine the output voltage v_0 for circuit (b) shown below

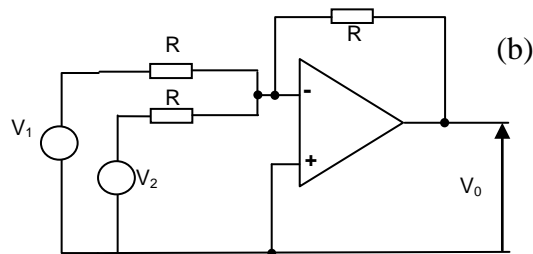

Problem Sheet 1 2011 - Answers

- Density = mass/volume so 1 mole of Cu occupies $63.54 \text{ g} / 8.92 \text{ g/cm}^3 = 7.123 \text{ cm}^3$ and contains 6.02×10^{23} Cu atoms. Thus the density of atoms is $6.02 \times 10^{23} / 7.123 = 8.45 \times 10^{22}$ atoms per cm^3 or 8.45×10^{28} atoms per m^3 and each atom supplies a free electron.
- Use $R = \rho L/A$: at 300K $R = 5.6 \times 10^{-8} \times 0.5 / 2 \times 10^{-9} \sim 14 \Omega$. At higher temperatures $\rho(T) = \rho_0 [1 + \alpha(T - T_0)] = 5.6 \times 10^{-8} [1 + 0.0045(2000 - 300)] \sim 121 \Omega$
- Total resistance is $(4+2) = 6 \Omega$ where $r = 2 \Omega$ is the internal resistance so the ammeter will read $I = 12/6 = 2 \text{ A}$. The voltmeter measures the difference between the battery emf, ϵ , and the voltage drop across the internal resistance: $(12 - 2.2) = 8$ volts. The rate of energy conversion, chemical to electrical, in the battery is $\epsilon I = 24 \text{ W}$. The power out of the battery is $I^2 r = 4 \times 2 = 8 \text{ W}$. You can check this by looking at the energy loss (dissipation) in the 4Ω resistor which is $4 \times 4 = 16 \text{ W}$.

- Although we generally assume that voltmeters have infinite resistance and ammeters zero resistance this is only an approximation. In reality they do have measurable values. The voltmeter measures the true voltage across R while the ammeter measures the current through R (I) and the voltmeter (I_V). The current through the voltmeter is given by Ohm's law as: $I_V = V/R_V = 1.2 \text{ mA}$ where R_V is the actual voltmeter resistance. Then $I_A = 100 = I + 1.2$ so the actual current through R is 98.8 mA and $R = 12/0.0988 = 121 \Omega$. Power dissipated in R is $12 \times 0.0988 = 1.19 \text{ W}$.

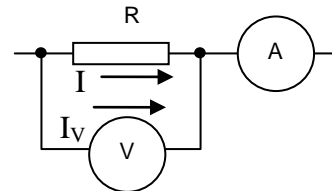

- Parallel connection means voltage across bulbs is the same. However the brightness is proportional to the power dissipation in each bulb (assume a resistance, R). So for bulb A, $P = \epsilon^2/R$, while for B and C, $P = \epsilon^2/(R+R)$, making these half as bright. Removing bulb A leaves a circuit resistance of $2R$ and the current is ϵ/R giving a power $P = (\epsilon/R)^2/R = \epsilon^2/R$, the same as for A before it was removed. Finally, removing bulb C and replacing A gives a circuit total resistance of $R/2$ and a current is $2\epsilon/R$ but split evenly between bulbs A and B so that each dissipates a power of ϵ^2/R and these bulbs as bright as A was originally.

Problem Sheet 2 - Answers

Kirchhoff's laws

- Kirchhoff's voltage law states that the sum of the voltages (sources and losses)

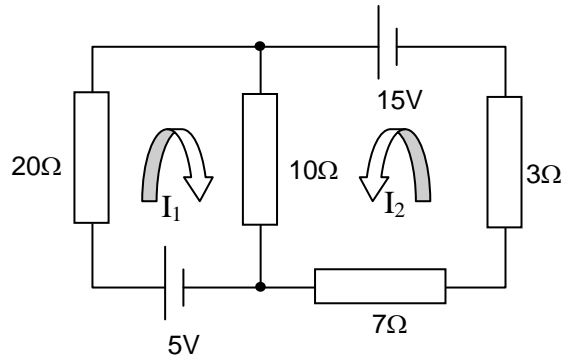

in a current loop is zero. This is a consequence of an electrostatic force being conservative. Kirchhoff's current rule applies to any node where wires meet and states that the sum of the currents at the node is zero. This is a consequence of conservation of charge. Each voltage supply is associated with a current loop I_1 and I_2 as shown and the direction of travel follows the conventional current rule. Since both currents go through the 10Ω resistor it carries $(I_1 + I_2)$ amps – this is a result of Kirchhoff's current law. For loop 1, apply Kirchhoff's voltage law to obtain: $5 - 20I_1 - 10(I_1 + I_2)$. Now repeat this for loop 2: $15 - 10(I_1 + I_2) - 7I_2 - 3I_2$. Solve these equations to get $I_{20\Omega} = 100$ mA, $I_{10\Omega} = 700$ mA, $I_{3\Omega} = I_{7\Omega} = 800$ mA.

- The principle of superposition allows the effect of each source to be considered independently. All you need to remember is (i) replace a voltage source with a short circuit and (ii) replace a current source with an open circuit. This gives two circuits as shown below. To find i' note that the 8mA is

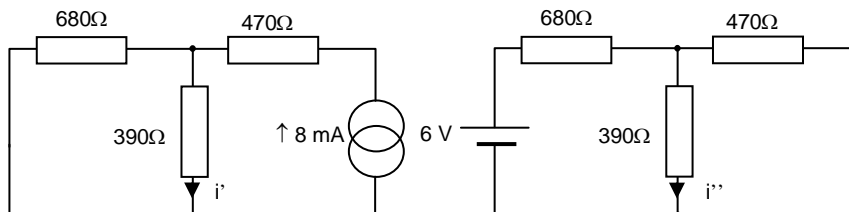

split between the 680Ω and 390Ω resistors – apply the current divider rule $i' = 680 / (680 + 390) \times 8 \text{ mA} = 5.1 \text{ mA}$. i'' is simpler, no current can flow through the 470Ω resistor so $i'' = 6 / (680 + 390) = 5.6 \text{ mA}$. Both currents travel in the

same direction so the total current in the 390Ω resistor is $(5.1 + 5.6) = 10.7\text{mA}$.

3. Principle of superposition: replace current source with an open circuit and the voltage source with a short circuit in turn. Taking the left hand circuit conventional current travels anti-clockwise from the 15V voltage source and has a value of $I' = 15/(20+10+10)\text{k}\Omega = 0.375\text{mA}$. For the right hand diagram must use the current divider rule and $I'' = 10/(10+10+20) \times 0.5\text{mA} = 0.125\text{mA}$ travelling clockwise.

Net current through upper $10\text{k}\Omega$ resistor is $I' - I'' = 0.25\text{mA}$ travelling anti-clockwise.

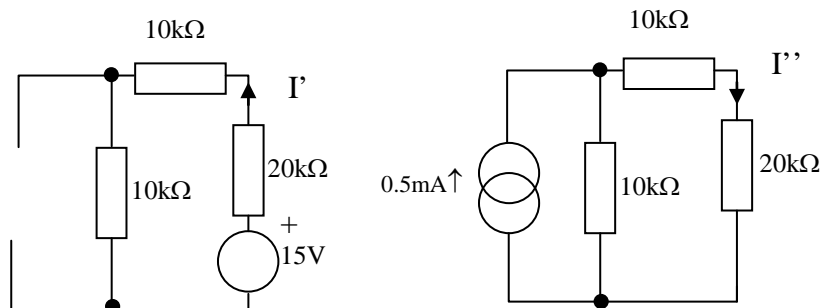

4. Find the open circuit voltage, V_{OC} . Think of putting a high resistance voltmeter across the output terminals marked AB; there will be no current flow through the voltmeter or through the 470Ω resistor i.e. A and X are at the same potential.

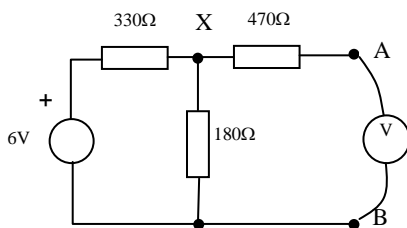

The circuit then becomes a simple voltage divider and taking the output across the 180Ω resistor this gives

$$V_{oc} = \frac{180}{(180 + 330)} \times 6 = 2.12\text{V}$$

Now find the short circuit current, I_{SC} . To do this, short circuit AB as shown in the right hand diagram. Now the 6V supply sees a 330Ω resistor in series with the parallel combination of the 470 and 180Ω resistors which together give a 130Ω resistor. This gives the total resistance of $330+130 = 460\Omega$ and a current of $6/460=13\text{mA}$. This is split between the 470 and 180Ω resistors and

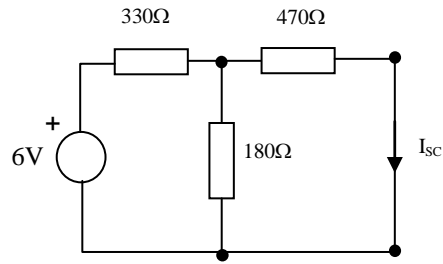

using the current divider rule this gives I_{sc} as $180/(180+470) \times 13 = 3.6 \text{ mA}$.

Since $R_s = V_{oc}/I_{sc}$ the source resistance is $2.12/3.6 \times 10^{-3} = 586\Omega$.

The Thévenin circuit then looks like:

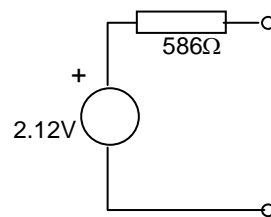

Electronics Problem Sheet 3 – Answers

1. $C = \epsilon_0 A/d = 8.85 \times 10^{-12} \times (10 \times 10^{-2})^2 \div 1 \times 10^{-3} = 88.5 \text{ pF}$. $Q = CV = 88.5 \times 10^{-12} \times 1000 = 8.85 \text{ nC}$. $E = Q/\epsilon_0 A = 10^6 \text{ V/m (N/C)}$ (alternatively just use $E = V/d$). The charge on the plates remains the same but the capacitance increases by a factor of 4.7 so V decreases to $1000 \div 4.7 = 213 \text{ V}$.
2. $C = \epsilon_0 A/d$ and $U = Q^2/2C$ so $U = \frac{Q^2 d}{2\epsilon_0 A}$. If d is now increased by a small amount, dx $U = \frac{Q^2 (d + dx)}{2\epsilon_0 A}$ so change in U is $U = \frac{Q^2 dx}{2\epsilon_0 A}$.
3. For the series combination the total capacitance is $CC/(C+C) = C/2$ so the stored energy is $U=CV^2/4$. For the parallel combination the total capacitance is $2C$ so the stored energy is $U=CV^2$ so ratio $U_P/U_C = 4$. For identical capacitors in series the charge on each is the same and each has a voltage $V/2$ (Kirchhoff's law) across the plates so the total charge is $CV/2 + CV/2 = CV$. For the parallel combination each capacitor sees a voltage V so the charge on each is CV and the total charge is $2CV$ so $Q_P = 2Q_S$.
4. (b) and (f) are true.
5. $\xi = -L di/dt = 0.26 \times 0.018 = 4.68 \text{ mV}$. Terminal a is at a higher potential.
6. (a) The maximum current obtained after long times is $25/50 = 0.5 \text{ A}$ (b) When the switch is closed the current increases as $i = \frac{V}{R} \left(1 - \exp^{-\frac{R}{L} t} \right)$ - inserting $i=V/2R$ gives the time to reach half the maximum current as $17.3 \mu\text{s}$ (c) $U = \frac{LI_{\max}^2}{2}$, so current when $U = U/2$ is 0.3535 A which occurs after $30.7 \mu\text{s}$.

Electronics Problem Sheet 4 – Answers

1. The average value for a period is given by:

$$(\text{area under curve})/\text{time} = \frac{1}{2} \times 2 \times 1 \times 10^{-3} / 1 \times 10^{-3} = 1 \text{ volt.}$$

To find the root mean square value first note that $v = 2 \times 10^3 t$ and substitute this in

$$\overline{v^2} = \frac{1}{T} \int_0^T v^2 dt \text{ to give } \overline{v^2} = \frac{1}{T} \int_0^T 4 \times 10^6 t^2 dt = \frac{4 \times 10^6}{T} \left[\frac{t^3}{3} \right]_0^T = \frac{4 \times 10^6 T^2}{3} \text{ and the r.m.s.}$$

$$\text{voltage is the square root, with } T=1\text{ms: } \sqrt{\frac{4 \times 10^6 T^2}{3}} = \frac{2 \times 10^3 T}{\sqrt{3}} = 1.155 \text{ volts}$$

2. DC and AC signals applied simultaneously. The instantaneous power is given by $P = V^2(t)/R^2 = (5 + 2.5 \cos(\omega t + \pi/4))^2 = 1/R[25 + 25 \cos(\omega t + \phi) + 6.25 \cos^2(\omega t + \phi)]$. Since the time averaged value of $\cos(\omega t + \phi)$ is zero and $\cos^2(\omega t + \phi) = 1/2(1 + \cos(2\omega t + \phi)) = 1/2$ then $P = 25 + 6.25/2 = 28.125 \text{ W}$.
3. $5 + j8.66$, $0.393 + j0.084$, $13 \times 10^3 + j7.5 \times 10^3$
4. Series inductor and resistor: $Z = R + j\omega L$. Parallel capacitor and resistor $1/Z = 1/R + j\omega C$
5. $v_{in} = 3 \sin(12566t)$ volts. The output will have the form $v_{out} = V_o \sin(12566t - \phi)$ volts. $\omega CR = 12566 \times 10 \times 10^{-9} \times 15 \times 10^3 = 1.885$. The phase angle ϕ is $\arctan(1.885) = 1.08 \text{ rad}$ (or 62°). The amplitude ratio $\frac{V_{out}}{V_{in}} \frac{1}{\sqrt{1 + \omega^2 C^2 R^2}} = 0.469$. Therefore $V_{out} = 0.469 \times 3 \text{ V} = 1.41 \text{ V}$. So $v_{out} = 1.41 \sin(12566t - 1.08) \text{ V}$.

Problem Sheet 5 2011 - Answers

1.

- (i) $v_0 = A(v_+ - v_-)$ where A is the amplifier gain
- (ii) Limits are ± 9 V
- (iii) $A(v_+ - v_-) = \pm 9$ V so $(v_+ - v_-) \sim 9/10^5$ and useful range $-90 \rightarrow +90 \mu\text{V}$
- (iv) Thévenin source will consist of an open circuit voltage source v_{OC} in series with a source resistance R_S . If the amplifier input resistance is equal to R_S then the input voltage to the amplifier is only $v_{OC}/2$. In order to ensure v_{OC} is input must have $R_{in} \gg R_S$
- (v) Similar argument – if $R_{out} \sim R_L$ output voltage is $v_0/2$. Must have $R_{out} \ll R_L$ to ensure maximum output voltage across R_L .
- (vi) $A = A_0 / (1 + jf/f_0)$ so $|A| = A_0 / (1 + (f/f_0)^2)^{1/2}$. (a) at $f = f_0$ $|A| = A_0 / \sqrt{2} = 0.7071 A_0$ (f_0 is known as the corner frequency or -3 dB point ($= 20 \log_{10}(1/\sqrt{2})$) that is 3 dB lower than A_0 ($= 100$ dB) and (b) $10 f_0$, $|A| = A_0 / \sqrt{101} \sim 0.1 A_0$ or 20 dB lower than A_0 : 80 dB.
- (vii) The graph shows a Bode plot already covered for the RC filter. The full

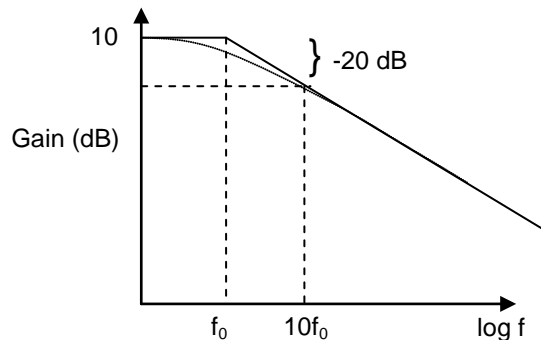

lines are close approximations to the curve (dotted line). By f_0 , $|A|$ has dropped by 3 dB, by $10 f_0$, $|A|$ has dropped by 20 dB. The slope is therefore -20dB per decade.

2.

- (i) $v_0 = A(v_+ - v_-) = A(v_{in} - v_0) = A/(1+A) \times v_{in}$. Since $A \gg 1$ this gives $v_0 = v_{in}$ and the amplifier exhibits *unity gain*.
- (ii) Substituting $A = A_0 / (1 + jf/f_0)$ gives $v_0/v_{in} = 1 / (1 + jf/A_0 f_0)$. So the gain has been reduced to 1 but the corner frequency (or bandwidth) is increased to $A_0 f_0$ and the gain \times bandwidth is constant.
- (iii) (a) 5 mV is d.c. and $v_0 = v_{in}$ (b) At $f = 10f_0$ ($= 20\pi$ rad/s) v_0 is still $= v_{in}$ (c) At $f = 10^5 \times f_0$, $v_0 = 0.7071 v_{in}$

3.

- (i) $v' = R_2 / (R_1 + R_2) \times v_{in}$
- (ii) $v_- = R_2 / (R_1 + R_2) \times v_{in}$
- (iii) $v_0 / v_{in} = (R_1 + R_2) / R_2$
- (iv) $v_0 = 10 V_{in} = 50$ mV. Invoking the gain-bandwidth product the frequency where the gain begins to drop is $10^4 f_0$

4.

- (i) Since the gain is high $v_+ \sim v_-$ and S must be at zero potential. This is the *virtual earth* approximation
- (ii) Current through R_{in} is $(v_{in}-0)/R_{in}$ and current through R_F is $(0-v_0)/R_F$ so $v_0/v_{in}=-R_F/R_{in}$
- (iii) $30\text{ k}\Omega$
- (iv) There are two input currents v_1/R and v_2/R . Kirchhoff's current law means these must add at the inverting input. Invoking the virtual earth approximation the total current must equal $-v_0/R$ so $v_0=-(v_1+v_2)$.